

Blood Management System



JMS SAGM - 100 ml
for collection of k odběru/ do pobraní/ kapacitet
za skupljanje/ za prikupljanje - 400 ml

Each SAGM contains: Oxidant (Phosphoric Acid) 6.000g, Mannitol 0.871g, Mannose 0.500g and Adipic acid 0.150g. Aqueous for 400 ml.

Ca: Dozvoljeno koristiti nakon izdavanja iz ambalaza i nakon sterilizacije.

Ca: uporabiti i/ili vložiti odmah nakon izdavanja i/ili sterilizacije.

PL - nie używać, jeśli wystąpiła jakaś awaria i/ili uszkodzenie.

FR - Ne pas utiliser, si vous constatez une anomalie ou un dommage.

RU - Не использовать, если обнаружены дефекты или повреждения.

DE - Nicht verwenden, wenn Beschädigung oder Defekt festgestellt wird.

2011-12

NON-PYROGENIC /
Apyrogenno / Neirogenno /
Apyrogeno / Apyrogeno

REF: 1911XXXX

LOT: 123456789

260-600

JMS CPDA-1 CORD BLOOD

Donor No: / Darov / Davač / Kan Alan Kurumi /
Davač broj / Noj Davačel broj

ABO: / Rh:

123456789 A

CE 0121

Caring for your health

JMS designs up-to-date
blood management products
with our patients and donors in mind.

About us

JMS started manufacturing blood bags in 1969 and have now over four decades of extensive and relevant expertise to meet the challenges presented in research, development and production of medical devices for blood transfusion applications.

Blood bags manufactured by JMS have a long and laudable reputation for reliability, superior product quality and assurance. Certified under EN ISO13485 Quality System, our fastidious production practices and high standards of quality control and measures in place are driven to ensure that our products meet the stringent requirements of blood banks and transfusion services which provide lifelines services to hospitals, patients and donors.

At JMS we believe in *total quality commitment and care*. This is our responsible management of whole blood and its components to ensure more effective use of precious blood resources for better health care in today's transfusion medicine.



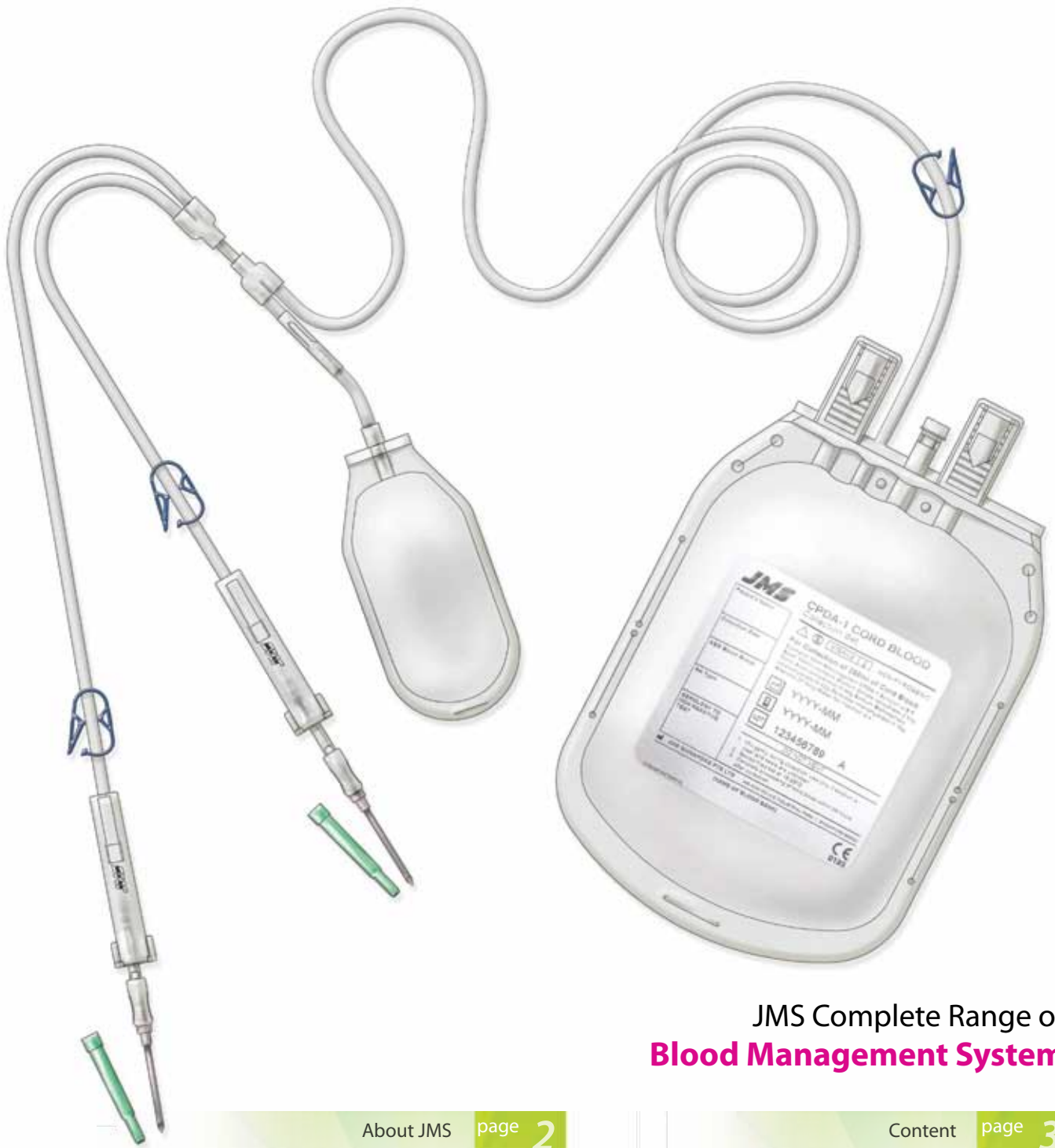

JMS Complete Range of Blood Management System

About JMS	page 2	Content	page 3
Safety Features	4	CPD-SAGM System	5
T-BEXS (CPD-SAGM)	6	Whole Blood In-line Leuko-Filtration System	7
Whole Blood In-line Filter	8	Dockable Red Cell Leuko-Filtration System	9
Cord Blood Bag Collection Set	10	Autologous Bag	11
Enhanced Features	12	Cellaid Serum Collection Bag	14
Platelet Storage Bag	15	Product Configurations	16
Blood Banking Accessories	23		



Safe and effective blood transfusion



Safety First. Our concern is not only to guarantee high quality of the blood components but also to provide maximum safety during blood donation and sample collection.



Convenience

JMS Integrated Blood Sampling Port

- Closed system & reusable blood sampling with vacuum tube
- Option to have lid

Reliability

JMS Blood Sampling Bag

- Storage container for convenient and contamination free sampling
- Volume of diverted blood could be used for laboratory testing

Safety

JMS Needle Protector

- Anti-stick device to provide healthcare workers and end-users maximum protection from needle stick injury



CPD-SAGM SYSTEM

The system consists of a primary bag containing anticoagulant CPD solution and one satellite bag containing SAGM (saline-adenine-glucose-mannitol) red cell preservation solution. This additive solution maintains red blood cell (RBC) viability and lowers the hematocrit of the RBC unit. Consequently JMS CPD-SAGM system can store RBCs for 42 days while maintaining 80% of post transfusion RBC survival rate.

This additive-solution system also allows larger volume of plasma to be collected. The removal of buffy coat and preparation of platelet concentrates from the buffy coat are easily achieved using this system. JMS CPD-SAGM system includes a bag with high gas permeability which enables it to store viable platelets for up to 5 days.



Superior red blood cell viability for 42 days storage

Increased plasma yield

Red blood cell flow property comparable to whole blood

Platelet storage for up to 5 days

T-BEXS (CPD-SAGM)

JMS T-BEX (Top and Bottom Extraction) System provides greater efficacy in the separation of blood components after centrifugation process. It is common for blood banks to use automatic processing machines to standardize and save manual labour in the extraction of quality Red Blood Cell, Plasma and Platelets from collected Whole Blood.

This system focuses on the use of the primary bag with Top and Bottom outlet ports which are mounted on the extractor unit after centrifuge. Using a single press operation, the Platelet-Poor-Plasma is transferred to the upper transfer bag and the Red Cell Concentrate is pressed concurrently into the lower bag that contains SAGM solution for the preservation of red cells. The buffy coat is retained in the primary bag for subsequent preparation of Platelets and Leukocytes.



Compatible with most commercial automatic extractors

Pre-attached blood sampling port for flexibility

Needle protector for enhanced user safety

WHOLE BLOOD IN-LINE LEUKO-FILTRATION SYSTEM

The world-wide demand for leuko-reduced whole blood has encouraged JMS to develop blood bag systems that meet the regulatory guidelines and strict requirements of blood banks especially in Europe and the US markets.

Reduction of leukocyte contamination in blood components is important to minimize various side effects such as non-hemolytic febrile transfusion reactions, transmission of leukocyte-borne virus and prevention of HLA alloimmunization and platelet refractoriness.

In line with our commitment to continuous improvement and safe patient care, we have designed a complete blood bag system for whole blood filtration that facilitates the handling in whole blood filtration to meet the EU Standards and AABB requirements regarding safe and efficient handling.

 **Start and forget,**
hands free

 **Safe and ease handling**
of system with in-line
filters

 **Ease of application**

 **Auto-venting loop**
system

 **Enhanced fluid**
recovery



WHOLE BLOOD IN-LINE FILTER

Rigorous and advanced tests in our JMS research and development institutes as well as in practical use of blood banks have shown that the LEUKOSEP® In-line Filter for whole blood combined with our well-established blood bag systems provide a high yield of plasma. This includes a yield of Factor VIII, excellent viability of red cells and removal efficiency of leukocytes.

Our certified production system includes strict quality assurance, guaranteed with a continuous high and consistent quality level. The steam sterilization of the complete system and efficient coiling of the bag, filter and tubes assure high integrity of the filter, which provides ease in handling for the donation team.

 **high yield of plasma**
- factor VIII

 **High efficiency of leukocyte removal**

 **excellent viability of red cells for 42 days storage**



Filter Performance

- $< 1 \times 10^6$ leukocytes per unit
- $< 0.8\%$ hemolysis
- minimum haemoglobin content of 40 g per unit
- $> 85\%$ red cell recovery
- Residual hold up volume $< 45\text{ml}$
- < 30 min filtration time

* Meeting the guidelines in the Council of Europe

▶ The multi layered ceramic based micro-fibres have proven in tests as well as in practise excellent performance in filtration of whole blood.

DOCKABLE RED CELL LEUKO-FILTRATION SYSTEM

JMS Leukoreduction and Storage Set for Red Cells is a sterile disposable device intended for reducing leukocytes from a unit of red blood cell. This design provides a safe, effective and convenient collection of red cells coupled with high efficiency leukocyte filtration processing.

State-of-the-art collection, filtration and storage



User-friendly, safe and fast handling of systems



Superb air venting system



Tubing compatible with sterile device connection

Application

Red Cell Concentrate

Volume

Derived from 1 unit of 450 - 500ml +/- 10% Whole Blood

Filter Performance Residual Hold Up Volume

< 45ml

Leukocyte Removal Rate

< 1×10^6 /unit

Red Cell Recovery

> 85%

Post Filtration Hemolysis

< 0.8%

Filtration Time

< 30 mins
(if processed at room temp)
< 1 hr
(if processed in 2-6 deg C)

Post Donation Storage Duration

=/< 5 days.
Maximum 8 hrs hold at temp prior to whole blood centrifugation

Post Donation Storage Temperature Performance Parameters

2 - 6 deg C

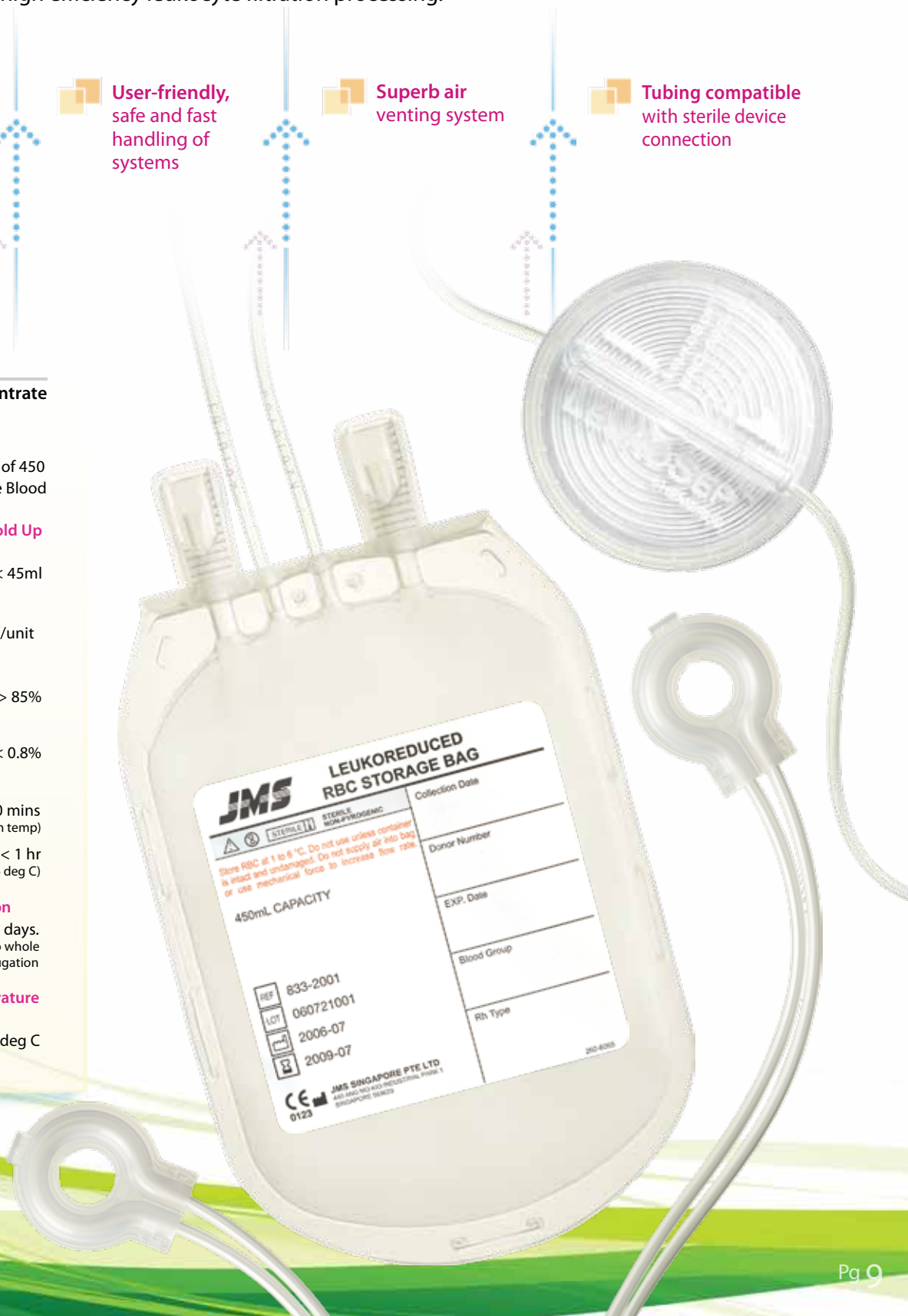

CORD BLOOD BAG COLLECTION SET

Cord Blood Bags are designed to collect the umbilical cord blood (also known as placental blood) after the birth of the baby, within the shortest time and minimal risk of contamination. The clinical use of the cord blood is allergenic transplantation in patients suffering from severe blood diseases such as leukemia, lymphoma, etc.

 **Tubing compatible with sterile device connection**



 **Specially tailored volume of anticoagulant**



 **Option to have double needles and integrated blood sampling port / sampling bag**



 **Ease of cleaning and water tolerance with polymeric labels**



 **Direct sampling with syringe. Ease in disinfection of port**



 **Safe blood collection using attached needle protector**



AUTOLOGOUS BAG

Auto-Transfusion is a process where patient receives his or her own blood instead of donor blood. This is a common practice for joint replacement surgeries and can be performed before, during or after surgeries.

During autologous blood donation patient donates his or her blood for own use, this process can commence up to 5 weeks before surgery, which will be stored and reinfused as needed during or after the surgery. As own blood is receptive to the body, it is an extremely safe way to help the patient in the recovery process.

JMS Autologous Bag is specially designed and used to store patient's own blood donation for such purpose.



Patient and Donor Safety is

With a renowned reputation for full comfort. JMS Blood Bags are manufactured including collection, separation, prese

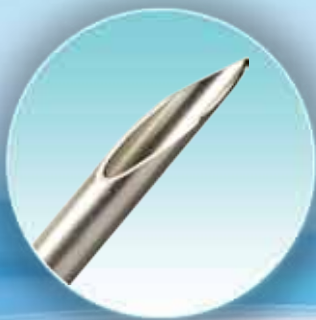
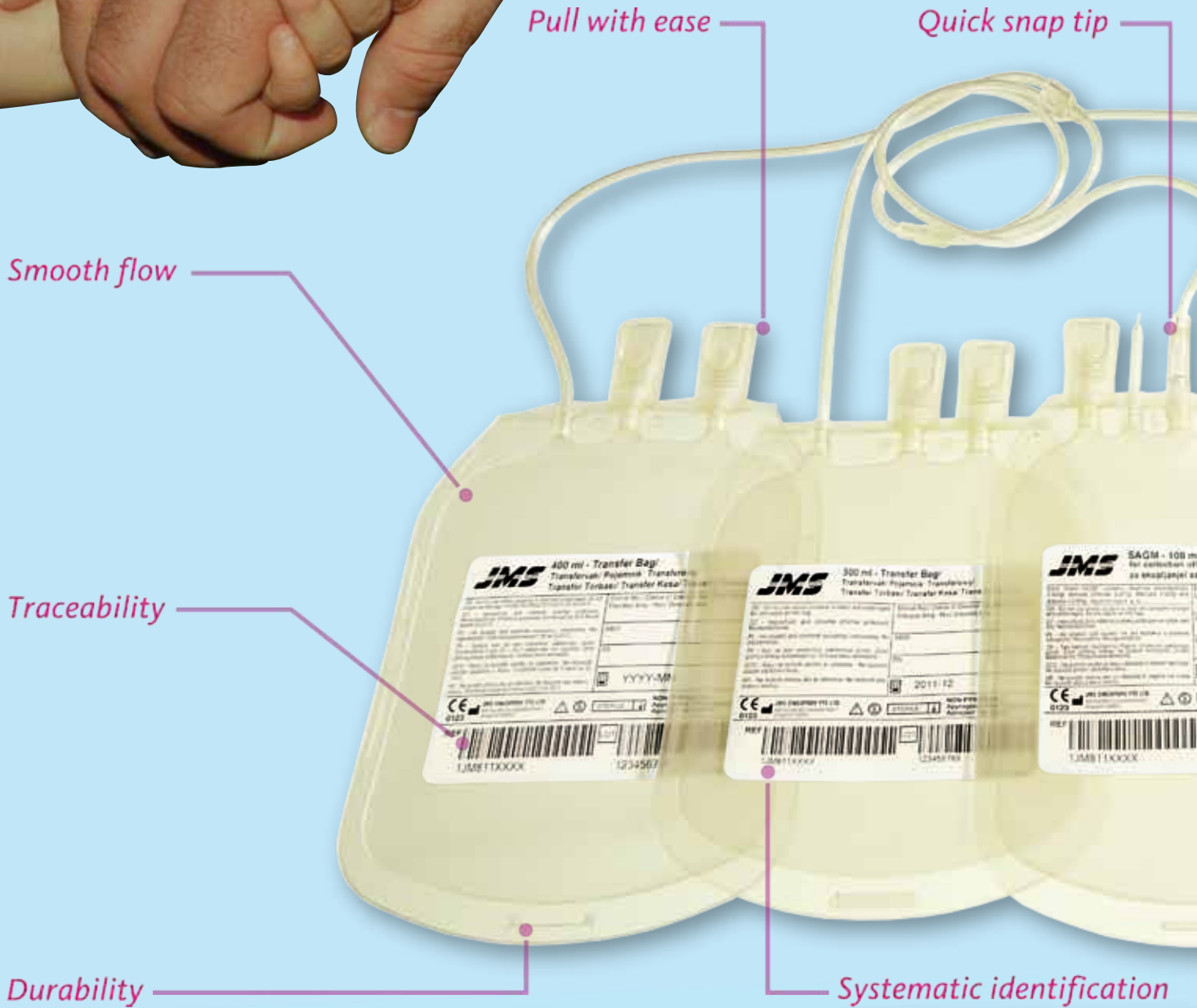

Needle Bevel

The oval slit is profiled to tip's geometry that has much smaller step for minimal tissue shaving and blood seepage during needle insertion.



Bag Label

Designed with polymeric tamper proof label, registered in ICCBBA and licensed to use ISBT 128 Bar Code for systematic identification.



Non-Stick Tubing

Compatible with universal tube sealer & sterile connecting device. Unique printed segment number for each unit.



Bag Profile

Rounded corners avoid friction, sm of blood compo separation & tran

our primary concern.

commitment to quality, reliability for our end users, maximum usage and
manufactured to the highest quality standards for optimum blood management
preservation and transfusion.

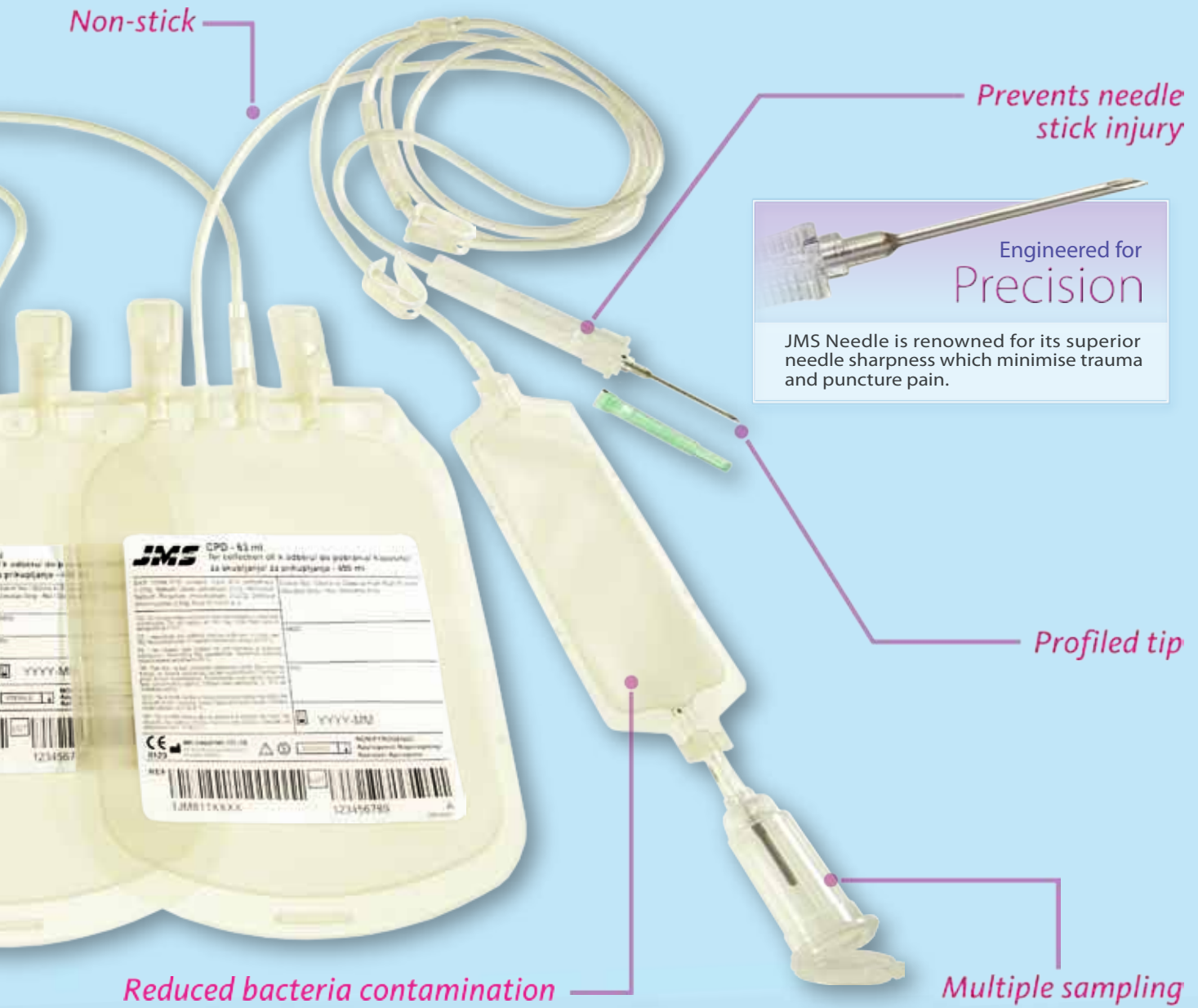

are designed to
transfer
components during
transfusion.

Easy Snap-Tip

Snap-tip enables ease of transferring blood components to satellite bags.

User Friendly Port Cover

Port cover can be pulled open with one hand, avoiding direct contact with the port itself.

Reliable Bag Material

Specially formulated and compounded in-house to meet required standards for elution, chemical and biological safety.

CELLAID SERUM COLLECTION BAG

The serum collection bag contains the platelet activation beads. When beads come into contact with the blood, they will absorb blood plasma proteins. The platelets will then adhere to the beads which will then be activated to release growth factors.

Growth Factor	PDGF-BB	TGF-B1	HGF	
Serum	100%	100%	100%	*Measuring method: ELISA method
Plasma	2.9%	7.4%	61.9%	



Safety design
Serum can be prepared in a completely closed system which reduces the risk of contamination and protects the user from coming into contact with blood.



Rich in growth factors
Platelet activation beads are included in the collection bag. Beads accelerate blood coagulation and release of growth factors from platelet.



Preparation within 1 hour
Specifically designed to prepare serum from fresh whole blood.



PLATELET STORAGE BAG

JMS new platelet storage bag with UPX-80 intends to maintain large amount of platelets over 4.0×10^{11} cells for at least 5 days. After 5 days storage in UPX-80, the indexes of platelets are kept in very good condition.

High Gas Permeability | In order to maintain aerobic metabolism of platelet in the bag, high gas permeability is one of the most important factors for platelet storage bags. The newly developed material UPX-80 has much higher gas permeability than currently available platelet storage bags and it allows to maintain an optimum pH balance during storage.

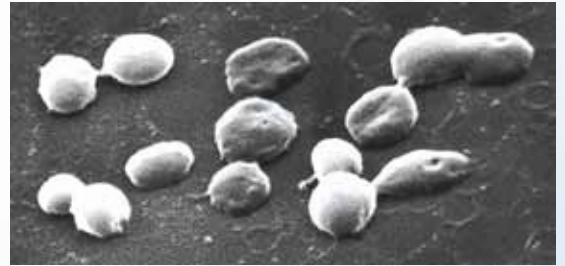

-Electron micrograph- Platelets after 5 days storage (X4000)



Product Configuration Blood Sampling System

CPDA-1 Solution

JMS Single Blood Bag

For whole blood collection, preservation and transfusion. When blood component separation is needed, JMS Transfer Bag can be connected as required.

Catalog Number	Primary Bag Capacity	Satellite Bag Capacity	Donor Needle Gauge Size
90-12-964-01	250ml	Super-Thin-Walled Ultra Sharp Needle Available in 16G or 17G	
90-13-964-01	350ml		
90-17-964-01	450ml		
90-15-964-01	500ml		
Optional Features			
*With or without accessories, T&T, BSB, NP, iBSP with or without lid			

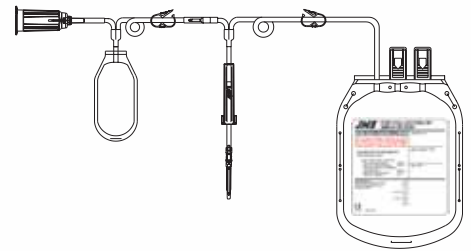

CPDA-1 Solution

JMS Double Blood Bag

For whole blood collection and separation of 2 different blood components (Red Blood Cell and Plasma) obtained through the process of centrifugation and extraction.

Catalog Number	Primary Bag Capacity	Satellite Bag Capacity	Donor Needle Gauge Size
90-22-964-01	250ml	Available in 150ml, 300ml, and 400ml	Available in 16G or 17G
90-23-964-01	350ml		
90-27-964-01	450ml		
90-25-964-01	500ml		
Optional Features			
*With or without accessories, T&T, BSB, NP, iBSP with or without lid			

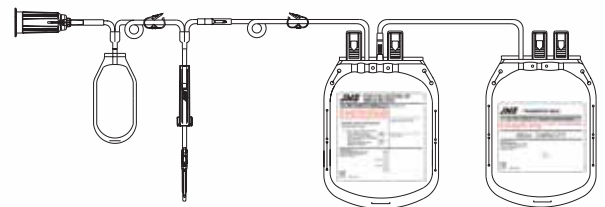

CPDA-1 Solution

JMS Triple Blood Bag

For whole blood collection and separation of 3 different blood components namely (Red Blood Cells, Plasma and a buffycoat that comprise of Leukocytes and Platelets), obtained through the process of centrifugation and extraction.

Catalog Number	Primary Bag Capacity	Satellite Bag Capacity	Donor Needle Gauge Size
90-32-964-01	250ml	Available in 150ml, 300ml, and 400ml	Available in 16G or 17G
90-33-964-01	350ml		
90-37-964-01	450ml		
90-35-964-01	500ml		
Optional Features			
*With or without accessories, T&T or T&B BSB, NP, iBSP with or without lid			

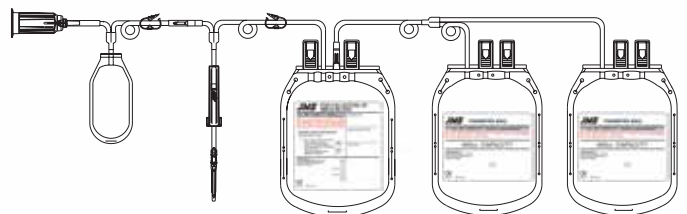

Product Configuration

Blood Sampling System

CPDA-1 Solution

JMS Quadruple Blood Bag

For whole blood collection and separation of 4 different blood components (Red Blood Cells, Plasma, Leukocytes and Platelets), obtained through the process of centrifugation and extraction. A specially configured transfer bag by JMS is incorporated to ensure the conservation of Platelets for 5 days.

Catalog Number	Primary Bag Capacity	Satellite Bag Capacity	Donor Needle Gauge Size
90-42-964-01	250ml	Available in 150ml, 300ml, and 400ml	Available in 16G or 17G
90-43-964-01	350ml		
90-47-964-01	450ml		
90-45-964-01	500ml		
Optional Features			
*With or without accessories, T&T or T&B BSB, NP, iBSP with or without lid			



CPD-SAGM Solution

JMS Triple Blood Bag

For whole blood collection and separation of 3 different blood components (Red Blood Cells, Plasma and a buffy-coat that comprise of Leukocytes and Platelets), obtained through the process of centrifugation and extraction. The primary bag contains anticoagulant CPD solution and one satellite bag with SAGM (Saline-Adenine-Glucose-Mannitol) solution for Red Blood Cell Preservation.

Catalog Number	Primary Bag Capacity	Satellite Bag Capacity	Donor Needle Gauge Size
90-33-764-50	350ml	Available in 150ml, 300ml, and 400ml	Available in 16G or 17G
90-37-764-50	450ml		
90-35-764-50	500ml		
Optional Features			
*With or without accessories, T&T or T&B BSB, NP, iBSP with or without lid			



CPD-SAGM Solution

JMS Quadruple Blood Bag

For whole blood collection and separation of 4 different blood components (Red Blood Cells, Plasma, Leukocytes and Platelets), obtained through the process of centrifugation and extraction. A specially configured bag by JMS is incorporated to ensure the conservation of Platelets for 5 days. The primary bag contains anticoagulant CPD solution and one satellite bag with SAGM (Saline-Adenine-Glucose-Mannitol) solution for Red Blood Cell Preservation.

Catalog Number	Primary Bag Capacity	Satellite Bag Capacity	Donor Needle Gauge Size
90-43-764-50	350ml	N.A	Available in 16G or 17G
90-47-764-50	450ml		
90-45-764-50	500ml		
Optional Features			
*With or without accessories, T&T or T&B BSB, NP, iBSP with or without lid			



Product Configuration Autologous Bag

CPDA-1 Solution

JMS Single Blood Bag

For whole blood collection and storage. This bag is designed to be re-used for transfusion by the same patient.

Catalog Number	Primary Bag Capacity	Satellite Bag Capacity	Donor Needle Gauge Size
90-13-964-55	350ml	Available in 150ml	Available in 16G
90-13-964-50	450ml		
Optional Features			
*With or without accessories, T&T or T&B BSB, NP, iBSP with or without lid			

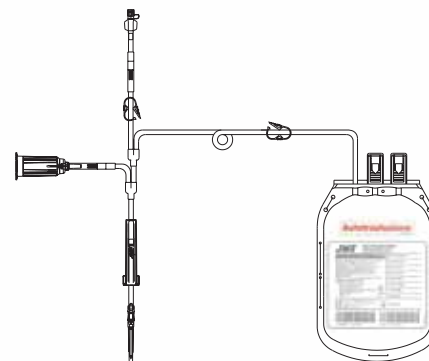

Cord Blood Bag

JMS Single Cord Blood Bag

For Cord Blood Collection.

Catalog Number	Primary Bag Capacity	Satellite Bag Capacity	Donor Needle Gauge Size
90-11-964-02	150ml	Available in 150ml	Available in 16G
90-12-964-02	250ml		

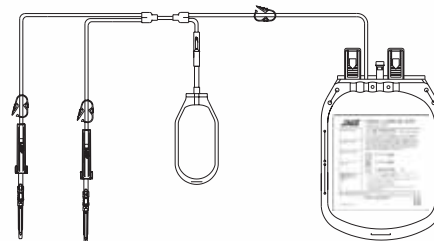

JMS Double Cord Blood Processing Bag

For Cord Blood Processing.

Catalog Number	Primary Bag Capacity	Satellite Bag Capacity	Donor Needle Gauge Size
90-21-964-02	250ml	Available in 150ml	Available in 16G

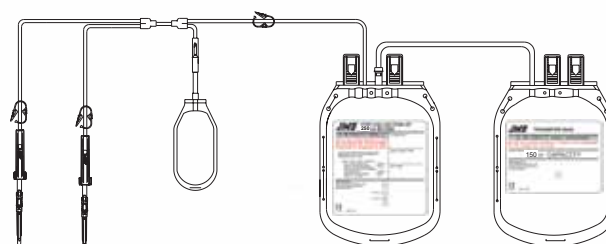

Product Configuration

T-Bex System

JMS Triple Blood Bag

For whole blood collection and separation of 3 different blood components (Red Blood Cells, Plasma and a buffy-coat that comprise of Leukocytes and Platelets), obtained through the process of centrifugation and extraction. JMS T-Bex System comprise of a specially configured primary bag containing anticoagulant CPD solution and one satellite bag with SAGM (Saline-Adenine-Glucose-Mannitol) solution for Red Blood Cell preservation.

Catalog Number	Primary Bag Capacity	Satellite Bag Capacity	Donor Needle Gauge Size
92-33-764-50	350ml	Available in 150ml, 300ml, and 400ml	Available in 16G or 17G
90-37-764-50	450ml		
90-35-764-50	500ml		
Optional Features			
*With or without accessories, T&T or T&B BSB, NP, iBSP with or without lid			

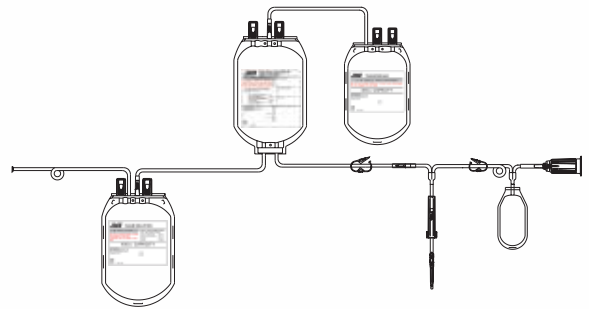

JMS Quadruple Blood Bag

For whole blood collection and separation of 4 different blood components (Red Blood Cells, Plasma, Leukocytes and Platelets), obtained through the process of centrifugation and extraction. JMS T-Bex System comprise of a specially configured primary bag containing anticoagulant CPD solution and one satellite bag with SAGM (Saline-Adenine-Glucose-Mannitol) solution for Red Blood Cell preservation. A transfer bag for platelets conservation for 5 days is incorporated.

Catalog Number	Primary Bag Capacity	Satellite Bag Capacity	Donor Needle Gauge Size
92-43-764-50	350ml	Available in 150ml, 300ml, and 400ml	Available in 16G or 17G
90-47-764-50	450ml		
90-45-764-50	500ml		
Optional Features			
*With or without accessories, T&T or T&B BSB, NP, iBSP with or without lid			

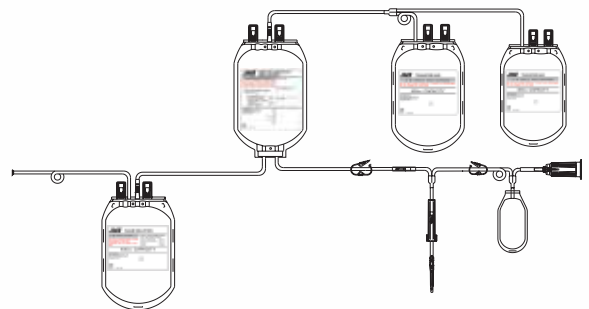

Transfer Bag

JMS Transfer Bag

Bag capacity of 150ml - 2000ml. For blood components from whole blood and procedures that further separates these components.

Catalog Number	Primary Bag Capacity	Standard Set
91-15-364-00	150ml	Two entry port and a single lead with a transfer spike
91-20-364-00	200ml	
91-30-364-01	300ml	
91-50-364-00	500ml	
91-60-364-00	600ml	
91-91-364-00	1000ml	

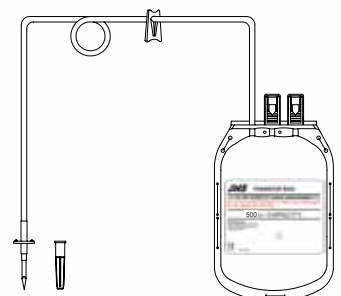

CPD-SAGM Solution

JMS Quadruple Blood Bag T-Bex

For whole blood collection and on-line filtration of whole blood components (Red Blood Cells and Plasma), obtained through the process of centrifugation and extraction.

Catalog Number	Primary Bag Capacity	Satellite Bag Capacity	Donor Needle Gauge Size
90-44-764-88	450ml	Available in 300ml and 400ml	Available in 16G and 17G
Optional Features			
*With or without accessories, T&T or T&B BSB, NP, iBSP with or without lid			

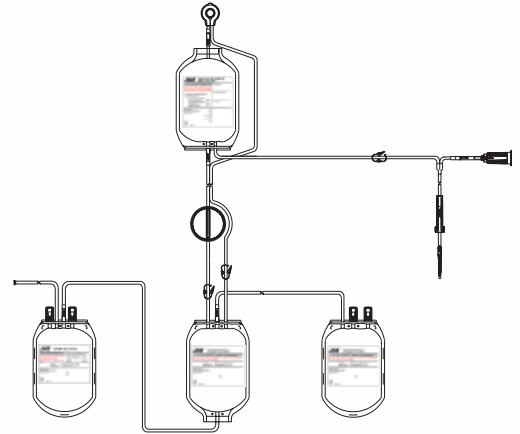

CPD-SAGM Solution

JMS Quadruple Blood Bag

For whole blood collection and on-line filtration of whole blood components (Red Blood Cells and Plasma), obtained through the process of centrifugation and extraction.

Catalog Number	Primary Bag Capacity	Satellite Bag Capacity	Donor Needle Gauge Size
90-44-764-77	450ml	Available in 300ml and 400ml	Available in 16G and 17G
Optional Features			
*With or without accessories, T&T or T&B BSB, NP, iBSP with or without lid			

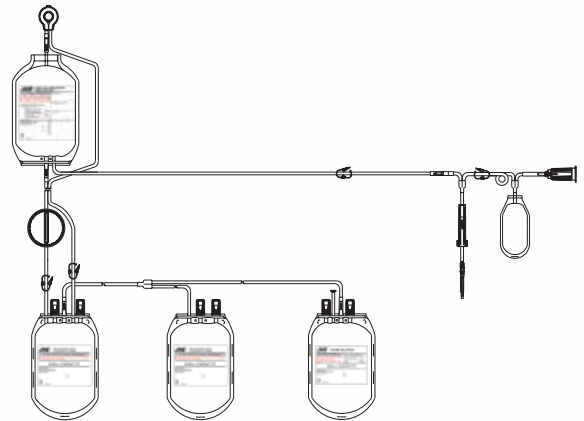

JMS Dockable Red Cell Leuko-Filtration System

Leukoreduction & Storage Set for Red Cell. For dockable of a pack of red cell and provide an on-line filtration of the red cell.

Catalog Number	Primary Bag Capacity	Satellite Bag Capacity	Donor Needle Gauge Size
90-88-000-01	450ml	Available in 300ml and 400ml	Available in 16G and 17G
Optional Features			
*With or without accessories, T&T or T&B BSB, NP, iBSP with or without lid			

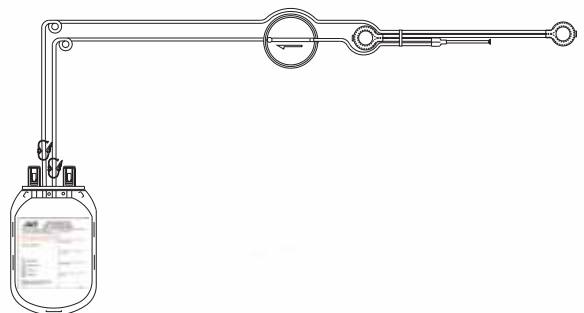

Product Configuration Transfusion Set

JMS Transfusion Set Type-5

JMS Transfusion Set Type-5 is designed for administration of whole blood and red cells or plasma from Blood Bag. Consist of a double chamber; the upper chamber with a blood filter and the lower chamber with a drip orifice. This configuration assures full utilization of the filter of the upper chamber and easy observation of drops in the lower.

Catalog Number	Standard Set
04-35-061-00	With Venous Needle
04-35-061-01	Without Venous Needle

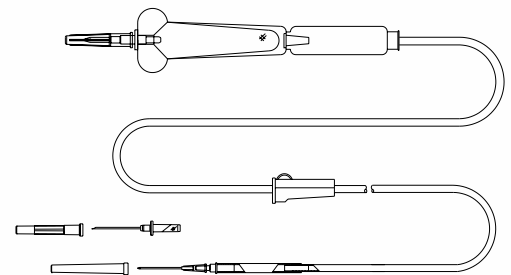

JMS Transfusion Set Type-Y

JMS Transfusion Set Type-Y is designed for simultaneous or alternate administration of blood and solution. The spike is designed to fit both the blood bags and solution bag.

Catalog Number	Standard Set
04-90-061-00	With Venous Needle
04-35-090-01	Without Venous Needle

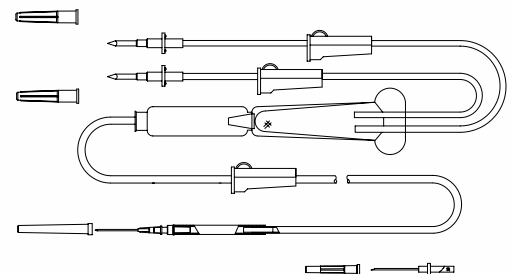

JMS Transfusion Set with Buret

JMS Transfusion Set with Buret for small volume blood transfusion is especially useful in neonatal, premature babies and pediatrics. The buret (volumetric chamber) is graduated in 1ml interval to allow precise blood volume control.

Catalog Number	Standard Set
04-80-061-80	With 100ml Buret
04-80-062-00	With 150ml Buret

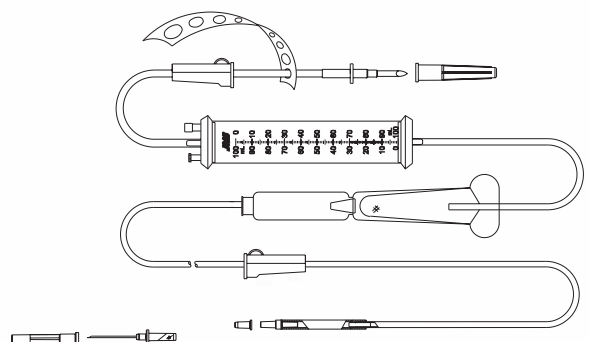

Product Configuration Platelet Storage Bag

JMS Platelet Storage Bag

A new generation of container with high oxygen permeability to maintain the aerobic metabolism of Platelets. The UPX-80 PVC material is designed to achieve an optimum PH balance during storage.

Type	Catalog Number	Primary Bag Capacity	Satellite Bag Capacity
Single Bag	90-70-130-00	1000ml	Available in 100ml
Double Bag	90-70-230-00	1000ml	

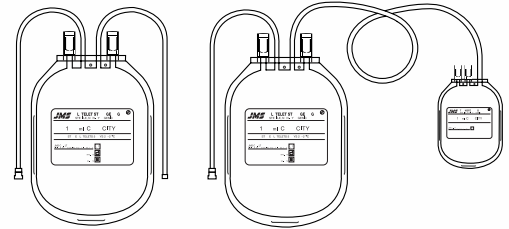

Plasmapheresis System

JMS Single and Multiple Plasmapheresis

For Plasmapheresis and collection of comparably larger volume of plasma. After centrifugation, plasma is extracted and the red cells returned to the donor through a blood returning port. Many important therapeutic products are derived from plasma including albumin and plasma protein fraction. JMS Plasmapheresis's systems are designed in Single Plasmapheresis (2 Bags) and Multiple Plasmapheresis (4 or 6 bags) Pack with maximum utilization of small donor pool. The primary bag contains anti-coagulant CPD solution.

Catalog Number	Primary Bag Capacity	Satellite Bag Capacity	Donor Needle Gauge Size
92-56-364-01	400ml	Available in 300ml, 400ml, and 500ml	Available in 16G or 17G
90-68-364-01	500ml		
90-66-364-01	600ml		
Optional Features			
*With or without accessories, T&T or T&B BSB, NP, iBSP with or without lid			

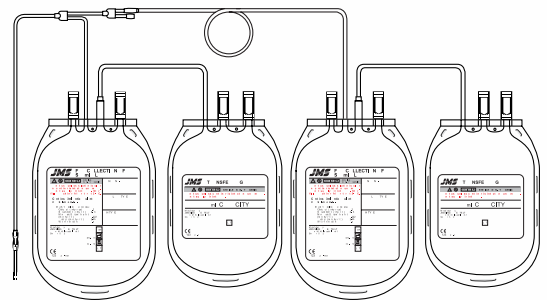

Packaging Configuration

The packing configuration of JMS Blood Bags are consciously designed for cost effective without comprising on the total integrity and sterility.



We innovate for a better tomorrow

JMS offers a full and complete range of blood banking accessories to complement the use of our blood bag products. With our state of the art research & development facilities we strive to offer unique and innovative solutions to meet the diversifying needs of healthcare market.



Complete Blood Banking Accessories

 Hemoscale



 Heavy Duty Hemosealer



 Portable Hemosealer

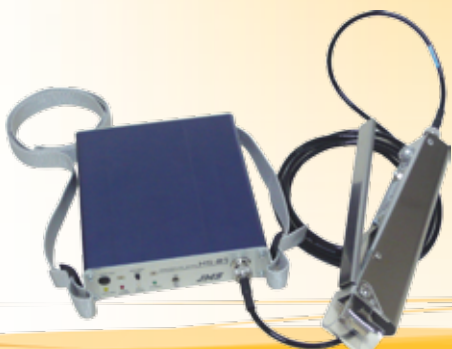

 Hand Sealer



 Platelet Incubator



 Complete Blood Banking Accessories



 Transfusion Chair



 Dual Press



 Plasma Extractor



Global market leader with worldwide distribution network



JMS Singapore is a global-oriented world class manufacturing plant, providing state-of-the-art health care products in Infusion Therapy, Dialysis System, Blood Management, Equipment & Accessories.

Asia

JMS CO., LTD

Tokyo Headquarters
Shin-Minamiohi Building
1-13-5 Minamiohi
Shinagawa-ku
Tokyo 140-0013
Tel : +81-(0)3-6404-0600
Fax: +81-(0)3-6404-0610

JMS Dalian Medical Supply Co., Ltd

25 Huanghaixi Road
Dalian Economic and Technical
Development Zone, Dalian,
People's Republic of China
Tel : +86-411-7613414
Fax: +86-411-7612300

Hiroshima Headquarters

12-17 Kako-machi, Naka-ku
Hiroshima-shi, Hiroshima-ken
730-8652
Tel : +81-(0)82-243-5844
Fax: +81-(0)82-243-5997

PT JMS Batam

Jl.Beringin Lot 211-212
Kawasan Industri Batamindo
Mukakuning
Batam 29433, Indonesia
Tel: +62-770-611-805
Fax: +62-770-611-806

JMS (K) Medical Supply Co., Ltd

547 Gasan-Dong,
Geumcheon-gu
Republic of Korea
Tel : +82-2-856-0518
Fax: +82-2-862-4598

JMS Singapore Pte Ltd

440 Ang Mo Kio Industrial Park 1,
Singapore 569620
Tel : +65-6457-1144
Fax: +65-6459-9564



**For more information please contact
us or your local distributor**

Copyright ©2010 JMS North America Corporation.
All rights reserved.

BRO/BB-E/001_R1

North America

JMS North America Corporation

Main Office
22320 Foothill Boulevard
Suite 350
Hayward, CA 94541, USA
Tel : +510-888-9090
Fax: +510-888-9099

Eastern Region Office

480 Sawgrass Corporate Parkway
Suite 120
Sunrise, FL 33325 USA
Tel : +954-689-9280
Fax: +954-689-9289

Europe

Bionic Medizintechnik G.m.b.H

Max-Planck, Str. 21, 61381,
Friedrichsdorf, Germany
Tel: +49-6172-7576-0
Fax: +49-6172-7576-10

Distributor